

Technical sheet :

M-X 30-2



	Technical characteristics		Metric
1.1	Manufacturer		Manitou
1.2	Model Name		M-X 30-2
1.3	Power source		Diesel
1.4	Operator type		Seated
1.5	Max. capacity	Q	3000 kg
1.6	Load centre of gravity	c	500 mm
1.8	Load distance, centre of drive axle to fork	x	697 mm
1.9	Wheelbase	y	2100 mm
	Weight		
2.1	Service weight		5090 kg
2.2	Weight on front axle (laden) / rear axle (laden)		7050 kg / 1040 kg
2.3	Weight on front axle (Unladen) / rear axle (Unladen)		2250 kg / 2840 kg
	Wheels		
3.1	Tyres type		Inflatable
3.2	Dimensions of front wheels		3.2: 440/80-24 8TN5 A325 168A8
3.3	Dimensions of rear wheels		10R17,5 G291 134M
3.5	Number of front wheels / rear wheels		2 / 2
3.5.2	Number of drive wheels		2
3.6	Front wheel gauge	b10	1670 mm
	Dimensions		
4.1	Tilt of Mast Forward (deg) / Backward (deg)	α / β	6 / 12
4.7	Height of overhead guard (cabin)	h6	2460 mm
4.19	Overall length	l1	4642 mm
4.20	Length to face of forks	l2	3630 mm
4.21	Overall width	b1	2100 mm
4.22	Forks section / width / length	s / e / l	125 mm x 1200 mm / 40 mm
4.23	Fork carriage ISO 2328 (class/form) A/B		FEM3
4.24	Fork carriage width	b3	1470 mm
4.31	Ground clearance below mast	m1	380 mm
4.32	Ground clearance at centre of wheelbase	m2	385 mm
4.35	Turning radius	Wa	3210 mm
4.36	Internal turning radius (over tyres)	b13	210 mm
	Performances		
5.1	Travel speed (laden / unladen)		24 km/h / 22 km/h
5.2	Lifting speed (laden / unladen)		0.5 m/s / 0.6 m/s
5.3	Lowering speed (laden / unladen)		0.5 m/s / 0.5 m/s
5.5	Drawbar pull (Laden / Unladen)		4830 daN / 1873 daN
5.10	Service brake		Hydraulic
	Engine		
7.1	Engine brand / model		Perkins / 1104D-44T NL38894
7.2	Engine power according to ISO 1585		70 kW
7.3	Rated speed		2360 rpm
7.4	Number of cylinders / Capacity of cylinders		4 - 4400 cm ³
	Miscellaneous		
8.1	Type of drive control		Hydraulic
8.2	Working hydraulic pressure for attachments		185 Bar
8.3	Oil flow rate for attachments		85 l/min

Dimensional drawing

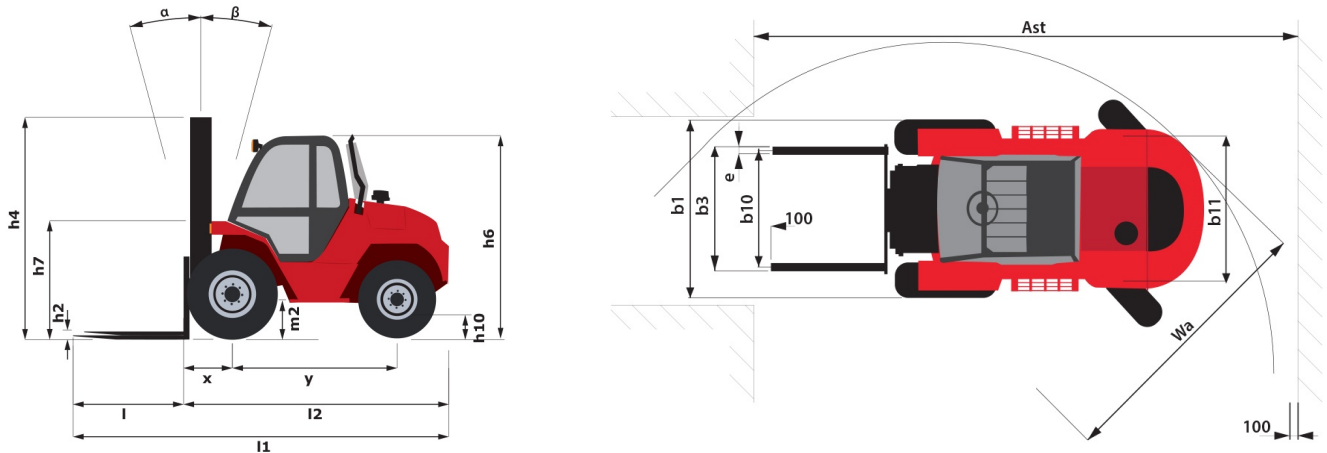

Characteristics of masts and residual capacities

Full Visibility Duplex		FVD 30	FVD 33	FVD 35	FVD 37	FVD 40	FVD 45	FVD 50	FVD 55
h1 - Height mast lowered *	mm	2375	2525	2625	2785	2975	3225	3475	3725
h2 - Free lift	mm	130	130	130	130	130	130	130	130
h3 - Lifting Height	mm	3030	3330	3530	4530	4530	4530	5030	5530
h4 - Height mast extended *	mm	4115	4415	4615	4815	5115	5615	6115	6615
α / β - Mast inclination (front / rear)	°	6 / 12	6 / 12	6 / 12	6 / 12	6 / 12	6 / 12	6 / 12	6 / 12
Residual capacity without attachment (Industrial load chart)	kg	3000	3000	3000	3000	3000	3000	3000	1600
Residual capacity with integrated side shift (Industrial load chart)	kg	3000	2000	3000	3000	3000	3000	1800	

Free Lift Triplex		FLT 37	FLT 40	FLT 43	FLT 47	FLT 50	FLT 55	FLT 60
h1 - Height mast lowered *	mm	2785	2375	2525	2625	2785	2975	3225
h2 - Free lift	mm	3740	1383	1533	1633	1793	1983	2233
h3 - Lifting Height	mm	3730	4040	4340	4740	5040	5540	6040
h4 - Height mast extended *	mm	4732	5032	5332	5732	6032	6532	7032
α / β - Mast inclination (front / rear)	°	6 / 12	6 / 12	6 / 12	6 / 12	6 / 12	6 / 12	6 / 12
Residual capacity at max height	kg		3000	3000	2100			
Residual capacity without attachment (Industrial load chart)	kg	3000	3000	3000	2100			
Residual capacity with integrated side shift (Industrial load chart)	kg	3000	3000	2500	1750	1500	1000	

Full Visibility Triplex		FVT 55
h1 - Height mast lowered *	mm	3055
h2 - Free lift	mm	0
h3 - Lifting Height	mm	5530
h4 - Height mast extended *	mm	6725
α / β - Mast inclination (front / rear)	°	6 / 12
Residual capacity without attachment (Industrial load chart)	kg	1500
Residual capacity with integrated side shift (Industrial load chart)	kg	1100



Siège Social
430 rue de l'Aubinière - 44150 Ancenis Cedex - France
Tel: +33(0)2 40 09 10 11 - Fax: +33 (0)2 40 09 10 97
www.manitou.com



This brochure describes versions and configuration options for Manitou products which may be fitted with different equipment. The equipment described in this brochure may be standard, optional or not available depending on version. Manitou reserves the right to change the specifications shown and described at any time and without prior warning. The manufacturer is not liable for the specifications given. For more information, contact your Manitou dealer. Non-contractual document. Product descriptions may differ from actual products. List of specifications is not comprehensive. The logos and visual identity of the company are the property of Manitou and may not be used without authorisation. All rights reserved. The photos and diagrams contained in this brochure are provided for information only.

MANITOU BF SA - Limited company with board of directors - Share capital: 39,668,399 euros - 857 802 508
RCS Nantes